



Proposal for Test of HL-LHC laser monitoring setup

M.Dejardin, F.Ferri, J-L. Faure, I.Kucher(*)

David Bailleux

(*) Part of her Thesis



LINKS



M.Dejardin

In **ECAL monitoring and calibration meeting**

Thursday, 28 August 2014

<https://indico.cern.ch/event/337420/>

J.L.Faure

WG4

ECAL Upgrade meeting

Tuesday, 28 January 2014

<https://indico.cern.ch/event/296610/contribution/1/material/slides/1.pdf>

ECAL monitoring and calibration meeting

Thursday, 30 January 2014

<https://indico.cern.ch/event/298637/contribution/4/material/slides/0.pdf>



Installation Scheme

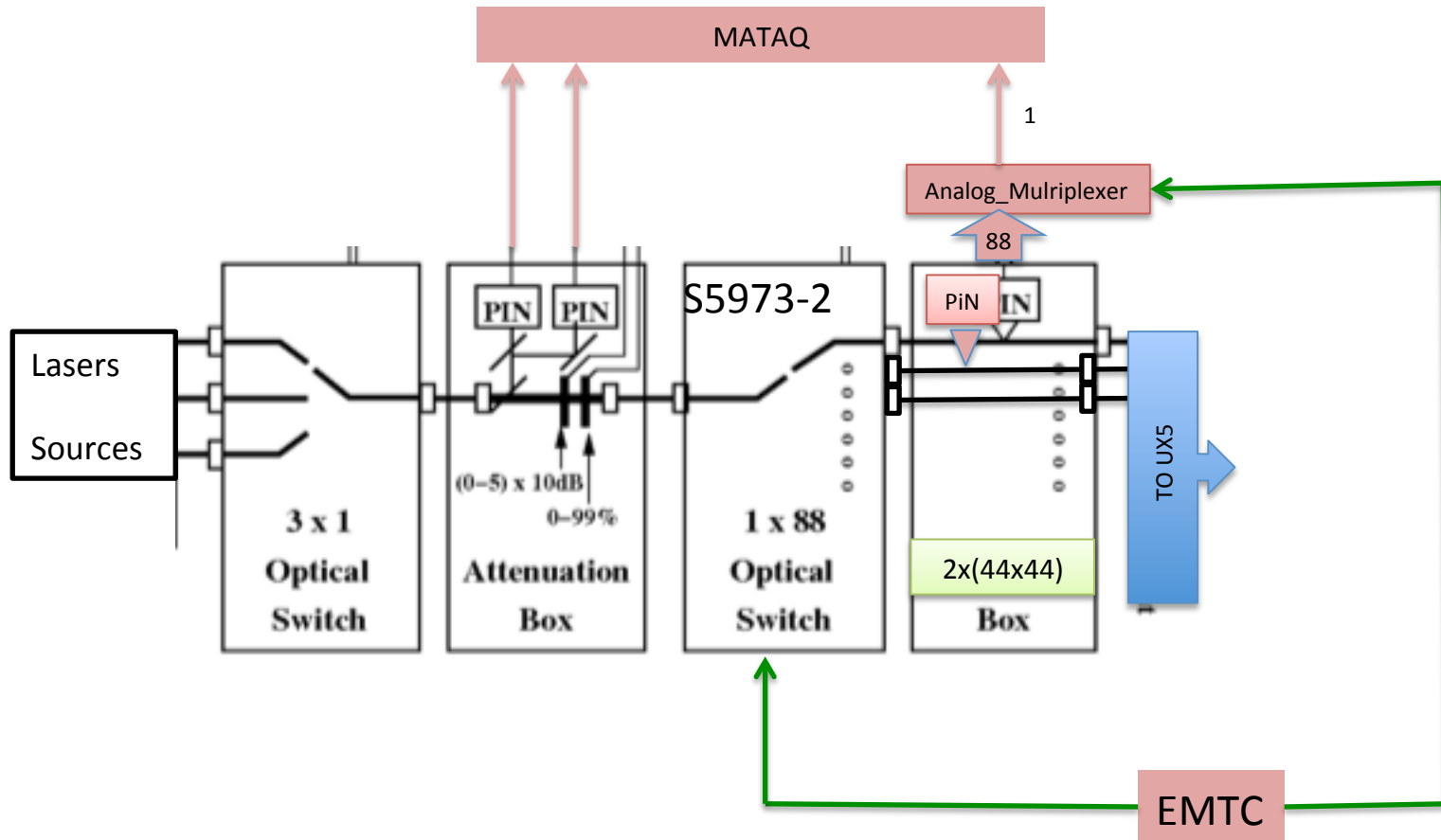



Light readout

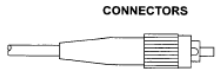

Stripped part

Optical fiber

PiN

PiN photodiode type ?

PiN Support and powering distribution plate

To Analog_Multiplexer

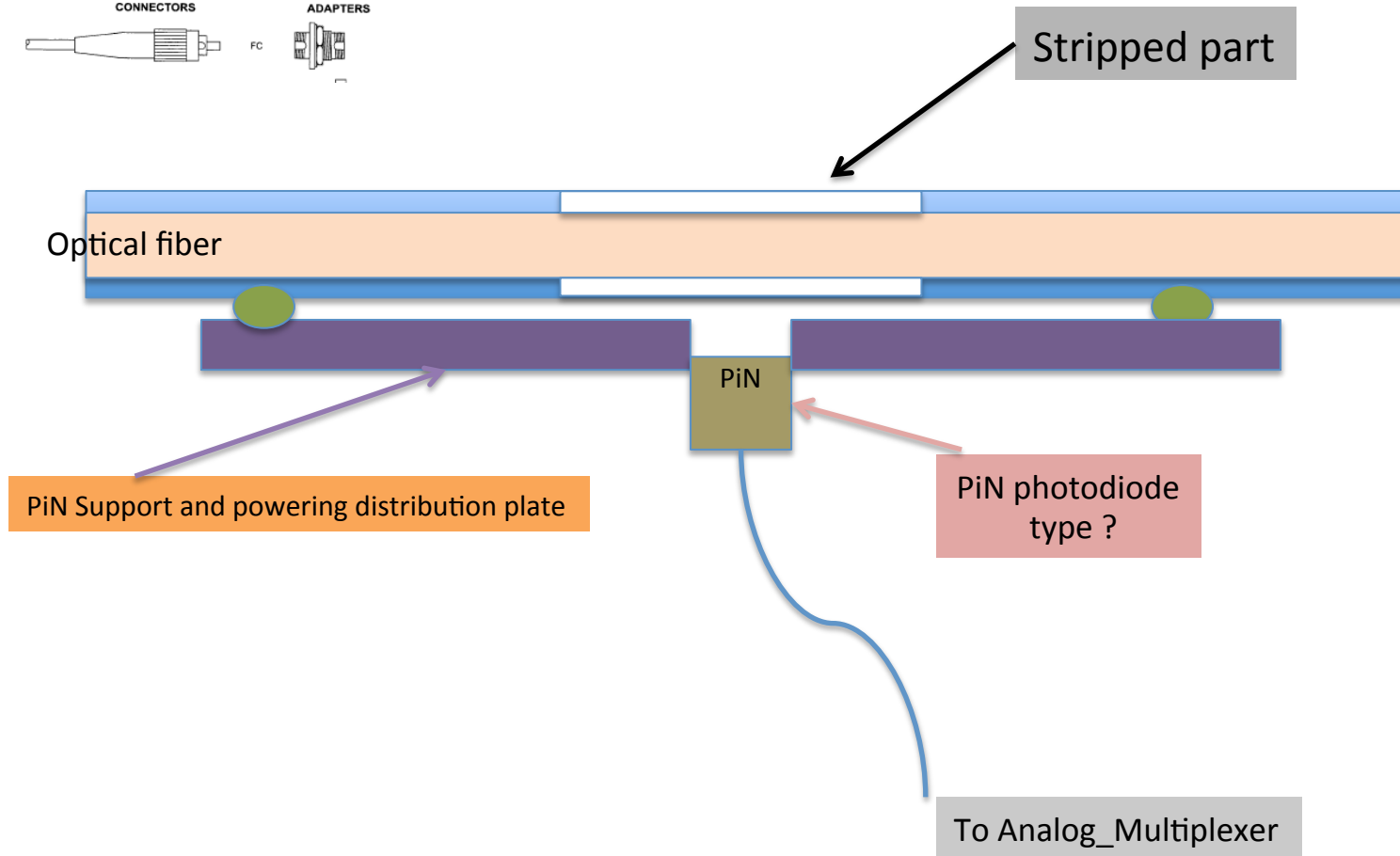



Spy-BOX

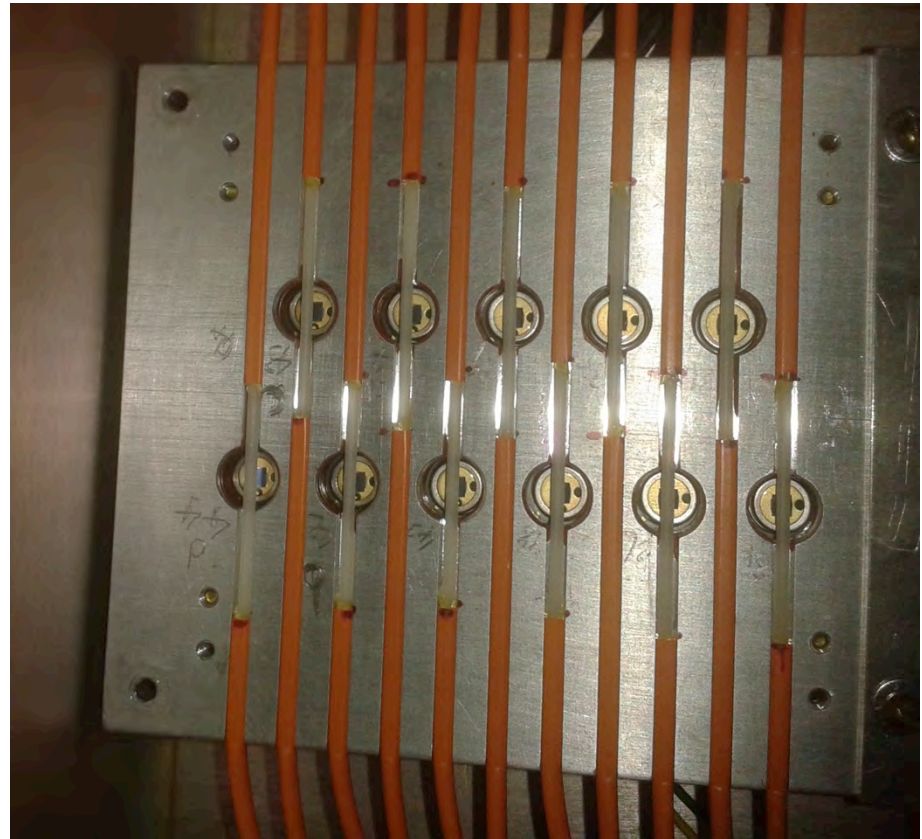
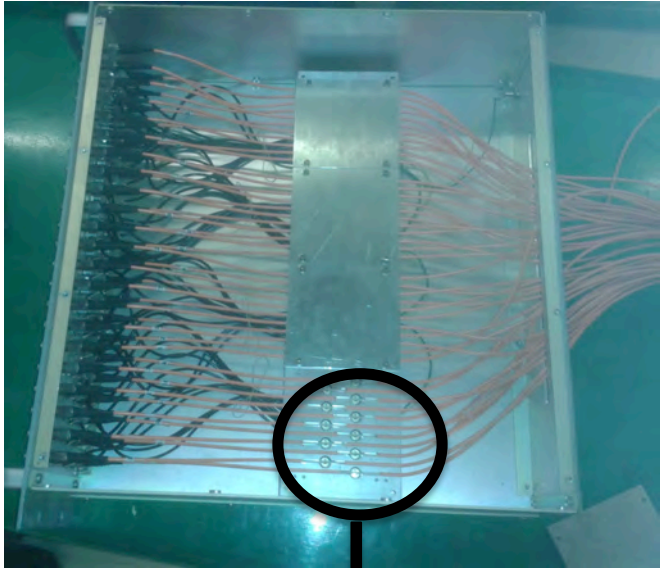

We have 2 boxes with 44 each



Proposed Actions I



Take a reference set of monitoring data points with the system as it is today

Install the 44x44 Spy-boxes

This will result to insert on the path of the light from the output of the 1x88 switch

1 meter of fiber (same type) and therefore 2 optical connectors

This will introduce minimal disturbance (>1db attenuation easily recoverable with laser power)

Take a new set of monitoring data
Check all channels



Proposed Actions II



Run with the 4 channel already equipped in parallel to the monitoring setup.

Using one of the 2 free input of the matacq

Case 1: The signal is strong enough

- Prepared the whole PIN boards
- Build a Multiplexer board 44 → 1
- Run in parallel (*) the 2 monitoring scheme

Case 2: The signal have to be amplified

- Study a PA
- Prepared the whole PIN boards/with PA
- Build a Multiplexer board 44 → 1
- Run in parallel (*) the 2 monitoring scheme

(*) The monitoring used for analysis will remain the one used so far.



Planning



Make this installation as as soon as possible when the running conditions are fulfilled

We had foreseen the week of Dec 15th to 19th

Perhaps because of CMS planning we should plan it in January



Backup





Spy-Box details I

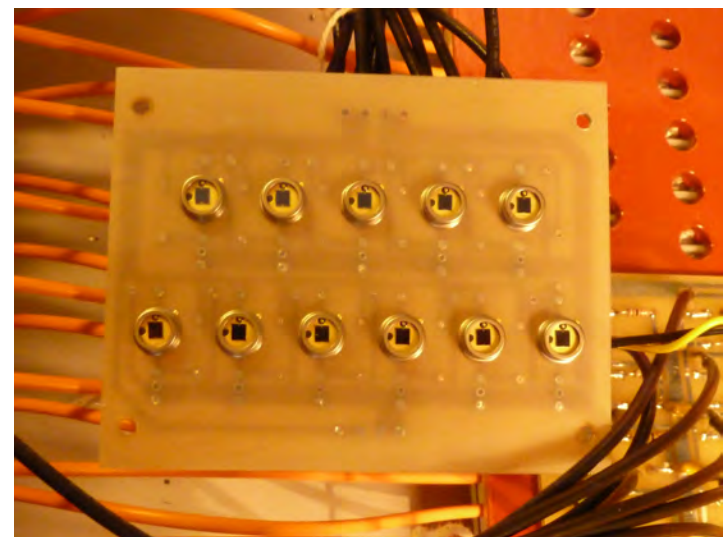
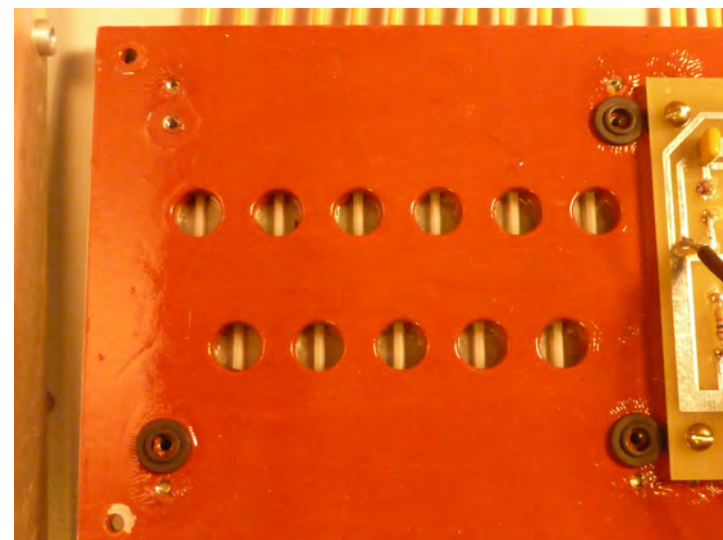
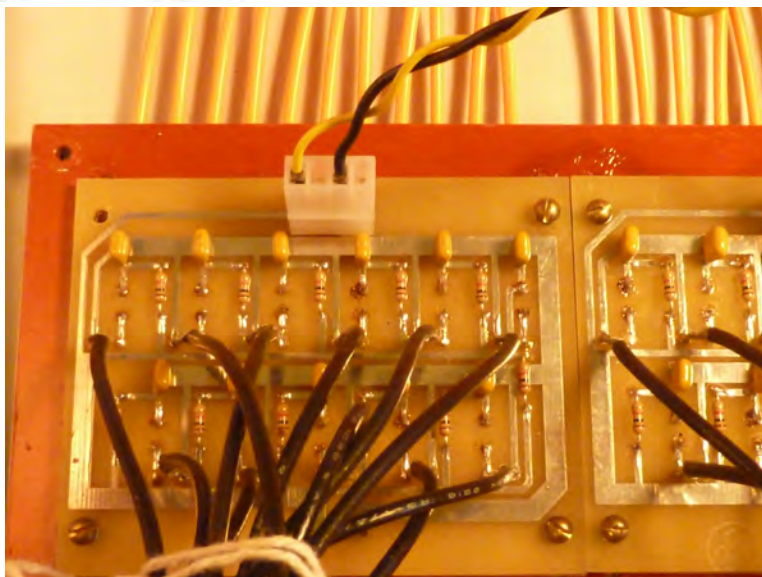

Spy--Box

44 stripped fibers

►4 boards with 11 fibers



Spy-Box details II



Setup

- PIN diodes
 - ▶ S1223
 - ▶ S5973
- Analog multiplexer
 - ▶ Development board from AD
 - ▶ 4- \rightarrow 1 mux
- Connection to PC
 - ▶ Numato 16 channels GPIO USB board (\$20)
 - ▶ Power from PC
 - ▶ Genuine LV=3.3V
 - Work also at 2.5V
 - Provide LV to mux and PIN

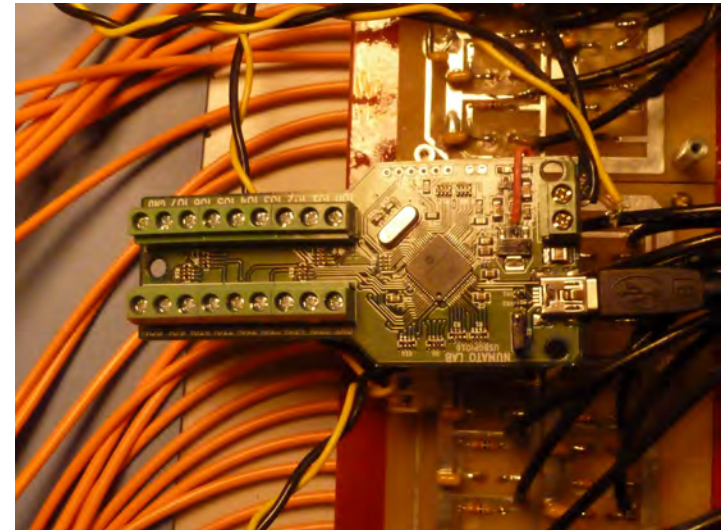
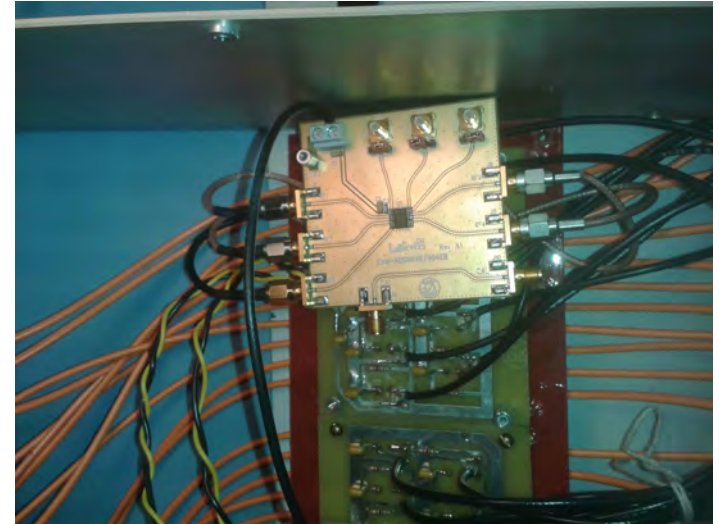

From M.Dejardin
MOCA meeting 28/8/2014



Spy-Box Test Results



- Measurements
- With S1223 PIN diode
 - ▶ Small signal seen
 - ▶ ~400 μV
 - Expected signal @ P5
 - ▶ 40 mV
 - ▶ Can be limit for analysis
 - ▶ Should be measured in situ
- With S5973 PIN diode
 - ▶ No signal seen
 - ▶ $0.4 \times 0.12 = 0.048 \text{ mm}^2$
 - ▶ Expect 1/140 of S1227 signal

Question:
Do we need Amplify signal at source

From M.Dejardin
MOCA meeting 28/8/2014

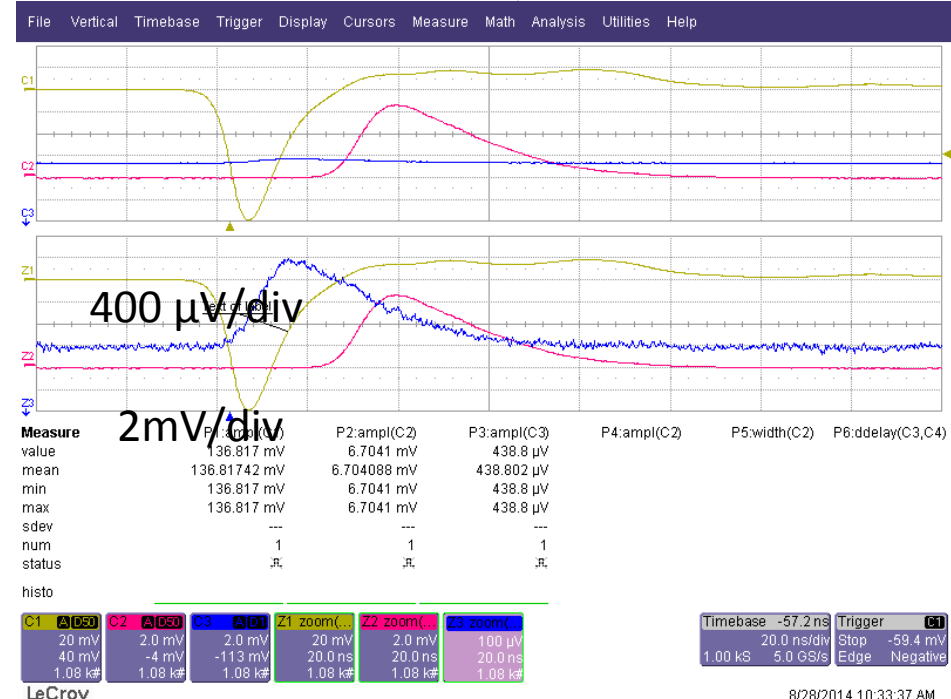
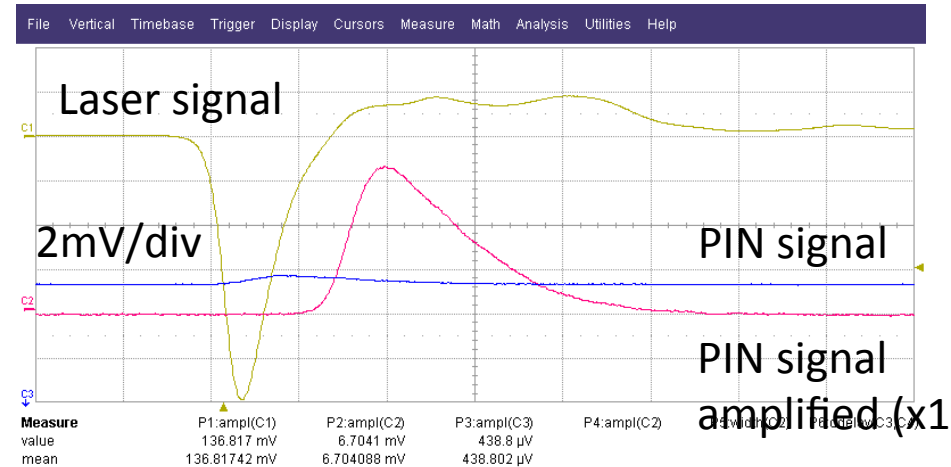

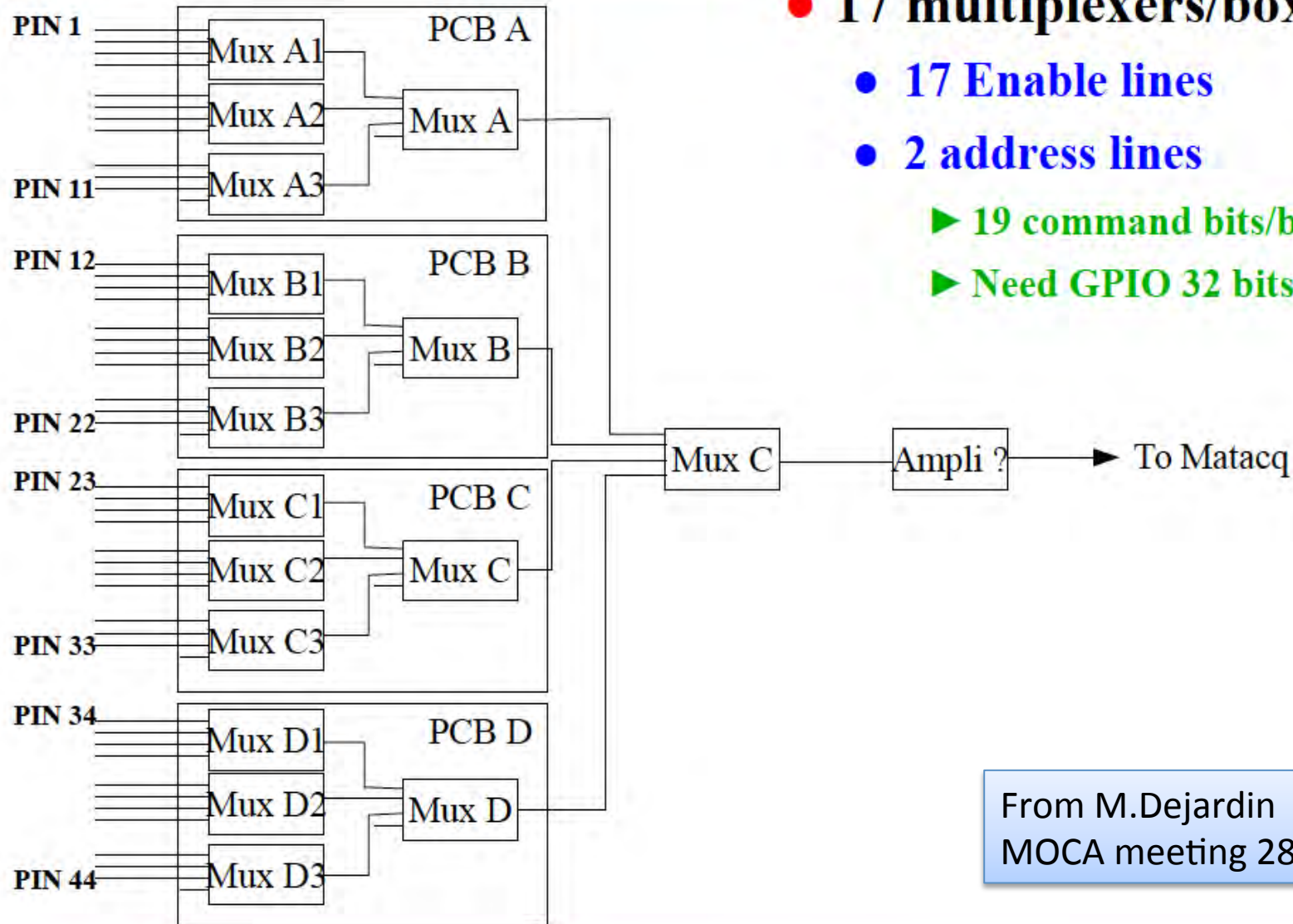

- **17 multiplexers/box**

- **17 Enable lines**

- **2 address lines**

- ▶ **19 command bits/box**

- ▶ **Need GPIO 32 bits module**

From M.Dejardin
MOCA meeting 28/8/2014