

# A Diode-Pumped DP2-447 Blue Laser for Monitoring CMS Lead Tungstate Crystal Calorimeter at the LHC

Kejun Zhu (On behalf of the CMS ECAL Collaboration)

**Abstract**—Monitoring the transparency of the lead tungstate crystals of the CMS electromagnetic calorimeter (ECAL) plays a crucial role in maintaining the ECAL energy resolution. To meet the stringent requirements on the light monitoring precision and stability a new commercial diode-pumped blue laser ("DP2-447") has been commissioned and installed at CERN for the 2012 operation of the CMS ECAL. The laser unit has a simple structure and is expected to be more reliable than the existing lamp-pumped lasers used by the monitoring system. The stability of critical quantities such as the intensity, width and timing, is better than that of the lamp-pumped lasers. The characteristics of the new blue laser will be elaborated. Its performance in-situ in CMS will be described and the prospects for improving the light monitoring precision will be discussed.

## I. INTRODUCTION

THE intrinsic width of the light Higgs is very narrow [1], so its discovery potential in the  $\gamma\gamma$  decay mode is directly related to the energy resolution of the Compact Muon Solenoid (CMS) electromagnetic calorimeter (ECAL) at the Large Hadron Collider (LHC) [2,3]. The 75,848 lead tungstate (PbWO<sub>4</sub> or PWO) crystals in the CMS ECAL suffer from dose rate dependent radiation damage. Precision calibration thus is crucial for the Higgs discovery. During the time needed to accumulate sufficient statistics for the inter-calibration by using physics events, PWO crystals experience radiation damage during beam on and recovery during beam off. In addition there are response losses in the Vacuum Phototriodes (VPTs) in the ECAL Endcaps ( $|\eta| > 1.48$ ). These effects are shown in Fig. 1 [4]. The changes of channel response *in situ* are corrected by using a light monitoring system which measures variations of crystal transparency and photodetector response at 440 nm [5].

A light monitoring system was designed and constructed by the Caltech and Saclay groups for the CMS PWO crystal ECAL [6]. Fig. 2 shows that the monitoring laser pulses of different color selected by a  $3 \times 1$  fiber optical switch are distributed via a  $1 \times 88$  switch to one of 88 calorimeter elements. A two stage distribution system mounted on each calorimeter element delivers monitoring laser pulses to each individual crystal. In the Barrel ECAL ( $|\eta| < 1.48$ ) the light is detected by Avalanche Photodiodes (APDs), in the Endcaps by the VPTs. The laser pulse energy measured by ECAL readout

is normalized to that measured by reference PN diodes. The APD/PN, or VPT/PN, ratio is the monitoring signal, which is a measure of the channel response. The monitoring signal must be measured to a precision of 0.2% to achieve a 0.5% inter-calibration precision.

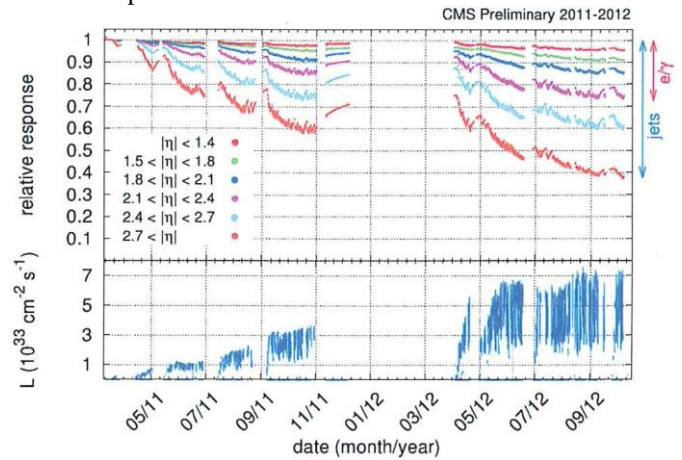

Fig. 1. History of monitoring response in 2011 for channels at different rapidity.

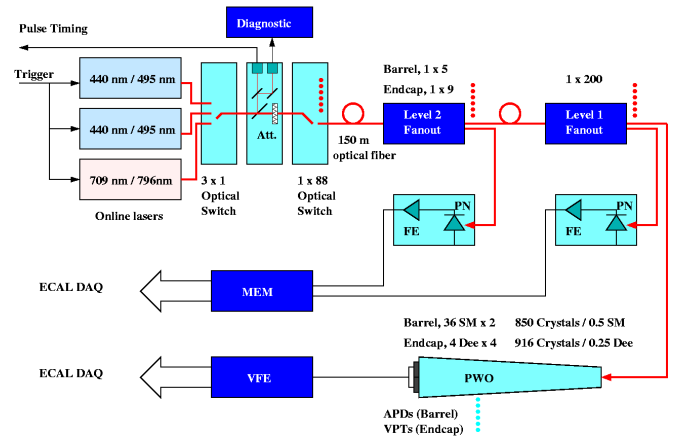

Fig. 2. A schematic showing the CMS ECAL laser system in 2011.

The CMS ECAL monitoring light source uses three Quantronix laser systems. Each laser system contains an Nd:YLF pump laser and a tunable Ti:S laser. The pump lasers provide frequency-doubled pulse at 527 nm with intensity up to 20 mJ. The tunable Ti:S lasers provide pulse intensity up to 1mJ at two wavelengths. Two monitoring laser systems provide four wavelengths: 440, 495, 709 and 796 nm. The third laser system (440 and 495 nm) is used as a spare to

Manuscript received November 18, 2012. This work was supported in part by the U.S. Department of Energy under Grant No. DE-FG03-92\_ER40701.

Kejun Zhu is with the California Institute of Technology, Pasadena, CA 91125, USA (e-mail: kejun@hep.caltech.edu).

guarantee 100% availability of the 440 nm. All three laser systems were installed at CERN in 2001 to 2003 for beam tests, and were moved to the underground CMS cavern in 2007 and 2008 for the LHC data taking.

All three lasers are pumped by DC Kr lamps, which degrade when aging. To address this issue a software feedback was introduced in 2006, which compensates the lamp aging effect by trimming the Nd:YLF laser pumping current [7]. Excellent stability at 3% level for the laser pulse energy, 4% for the laser pulse width and 2 ns jitter for the laser pulse timing were observed. However, additional issues came up during the LHC operation. Quantronix discontinued lamp pumped Nd:YLF laser in 2005. Since then replacement parts for the laser system are no longer available. (Quantronix is actually merged into Continuum in 2012 and left the ns laser market.) Laser intervention (monthly lamp changing and tuning) caused steps in monitoring responses. A stable blue laser with no need for frequent maintenance intervention was therefore required. A decision was made to procure a diode-pumped solid state (DPSS) blue laser system for the 2012 LHC run with the following specifications.

- 1) Pulse intensity: 1 mJ/pulse, which is equivalent to a mean electron signal of 1.3 TeV in each crystal.
- 2) Pulse intensity instability: < 3%.
- 3) Pulse FWHM: < 30 ns to match ECAL readout.
- 4) Pulse width instability: < 5%.
- 5) Pulse jitter: < 3 ns for synchronization with LHC.
- 6) Pulse repetition rate: 0-100 Hz, scan of full ECAL in 20 minutes.
- 7) Immune to stray magnetic field of 30 Gauss.

Following a market survey and vendor visits, Photonics DP2-447 DPSS blue laser was selected in November, 2011, and was delivered to Caltech in February, 2012. After a short period of integration at Caltech it was successfully commissioned at CERN in March, 2012.

## II. DP2-447 LASER AT CALTECH

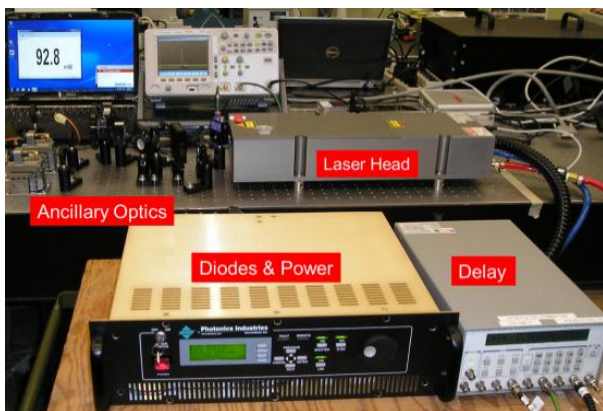

Fig. 3. DP2-447 laser and its ancillary optics.

Photonics DP2-447 is a proprietary DPSS laser based on intra-cavity third harmonic generation (THG) technology. It is

designed to be robust and compact with no user alignment required. It consists of a hermetically sealed laser head, a diode and power supply unit, a chiller and a delay unit which provides two external triggers for the pump diode and the Q-switch. Fig. 3 shows the laser and some of its ancillary equipment at Caltech. The expected mean time between failures (MTBF) for the DPSS laser is shown in Fig.4. It is longer than 1 year for 24/7 operations. This long MTBF indicates that maintenance related interventions, which cause steps in the monitoring response, could be avoided.

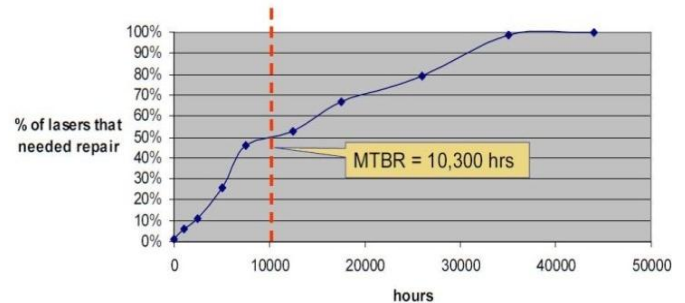

Fig. 4. The expected reliability of DPSS lasers. Courtesy of Photonics, Inc.

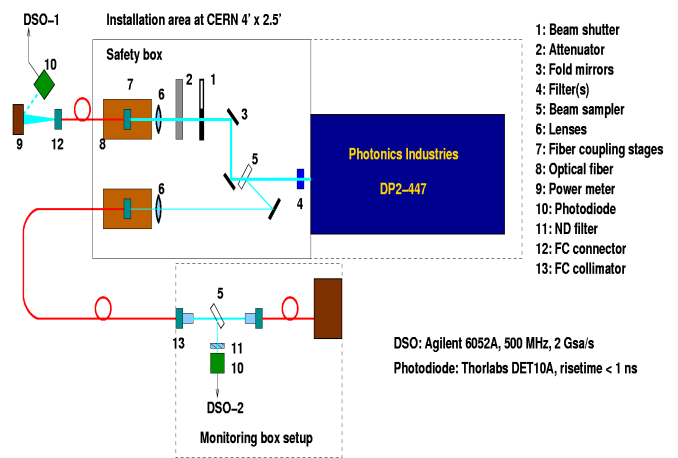

Fig. 5. The set-up used at Caltech to evaluate the laser performance.

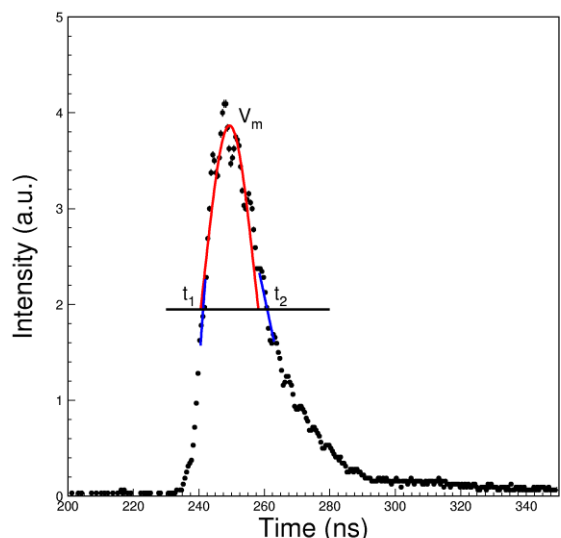

Fig. 6. DP2-447 laser pulse shape and its reconstruction.

Fig. 5 shows a schematic for the set-up used for laser evaluation at Caltech. The laser pulse was measured by a photodiode (labeled 10 in Fig. 5) which was read out by a digital oscilloscope DSO-2 (Agilent 6052A, 2GS/s). A typical laser pulse shape is shown in Fig. 6. The vertical jitter on the pulse shape, or intrinsic noise, is caused by the oscillation of the pulse inside the laser cavity. The algorithm used for the laser pulse reconstruction is as follows.

- 1) Find peak  $V_m$ ,
- 2) Find time at  $V_m/2$ :  $t_1$  and  $t_2$ ,
- 3) Gaussian fit between  $(t_1, t_2)$ ,
- 4) Calculate pulse intensity:  $\Sigma y_i$  between  $(V_m-4\sigma, V_m+8\sigma)$ ,
- 5) Calculate pulse center timing:  $\Sigma t_i y_i / \Sigma y_i$  between  $(-4\sigma, 8\sigma)$ ,
- 6) Calculate pulse width by a linear fit of 5 points (2 before and 2 after) at  $t_1$  and  $t_2$  to find  $t_{1f}$  and  $t_{2f}$  at  $V_m/2$  as well as  $FWHM = t_{2f} - t_{1f}$ .

The calculated pulse energy is calibrated by using a power detector inserted between the blue filter (4) and the beam sampler (5). All measurements were carried out with the default trigger setting: the pump diode is on for 88  $\mu s$  and the Q-switch is turned on at 86  $\mu s$ .

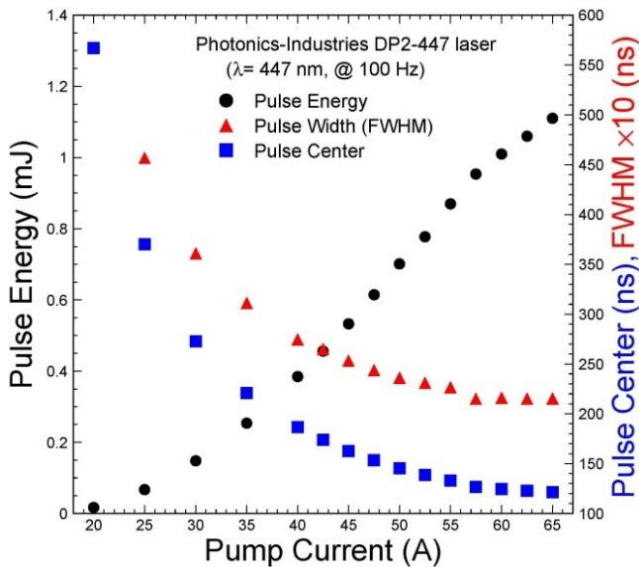

Figure 7. Pulse energy, width and center timing are shown as a function of the diode pump current.

Fig. 7 shows the pulse energy, width (FWHM) and center timing as a function of the diode pump current. Their instability (RMS) as a function of the diode pump current is shown in Fig. 8. While the pulse energy reaches the 1 mJ at 60A, the DP2-447 laser meets all other specifications with its diode pump current as low as 35A. This indicates that this laser can be run at a low pump current to prolong the lifetime of the diodes and other optical components if 1 mJ is not needed.

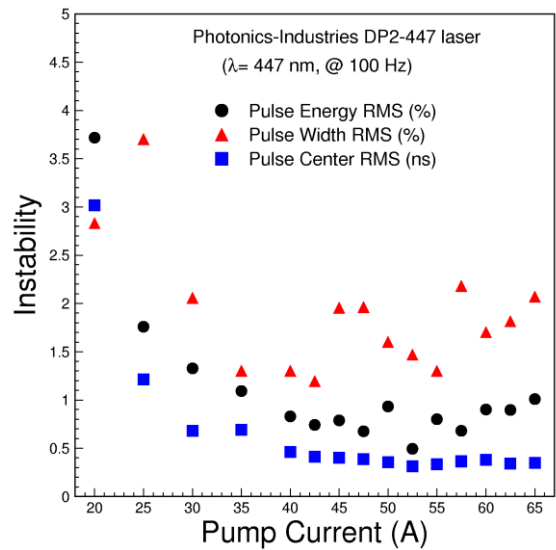

Figure 8. Instabilities of the pulse energy, width and center timing are shown as a function of the diode pump current.

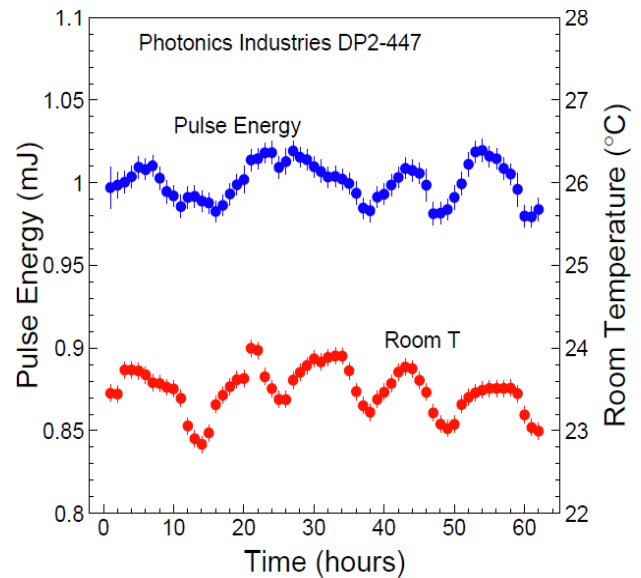

Fig. 9. Histories of the laser pulse energy and the room temperature are shown for sixty hours.

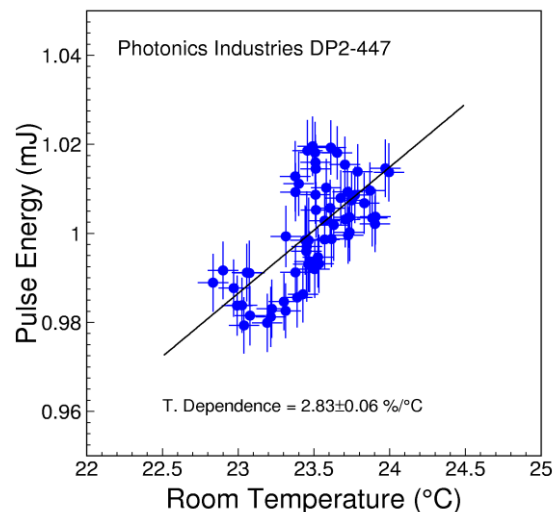

Figure 10. The temperature dependence of the laser pulse energy.

Fig. 9 shows variations of the laser pulse energy and the room temperature in a test run of about 60 hours. The corresponding temperature dependence was determined to be about 2.8%/°C, as shown in Fig. 10. This means that the room temperature in the laser barracks needs to be stabilized to 1°C to maintain the pulse energy stability at a level of 3%.

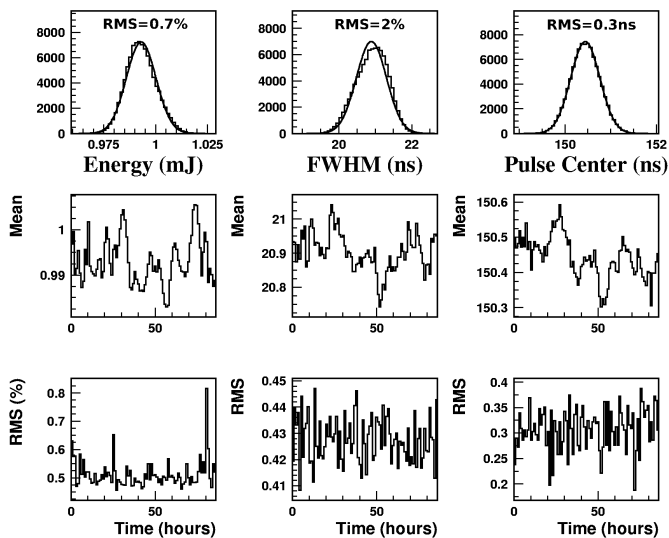

Fig. 11. History of laser pulse energy, width and center timing are shown for a run of 85 hours.

The result of a long run for 85 hours is shown in Fig.11. The observed stabilities are 0.7%, 2% and 0.3 ns respectively for the pulse energy, width and centre timing. They are much better than the 3%, 4% and 2 ns observed for the lamp-pumped Quantronix lasers [7]. All parameters measured are well within the specifications.

### III. DP2-447 LASER *IN SITU* AT LHC

The DP2-447 laser system arrived at CERN on March 20, 2012, and was installed in the CMS underground cavern on March 21. Its power was found to be consistent with that measured at Caltech, indicating no effect from the residual magnetic field at a level of 30 Gauss. Following that, the ancillary optics and monitoring fibers were installed. The DP2-447 laser system was finally integrated into the existing monitoring system as shown in Fig. 12. As with the Quantronix laser systems, the DP2-447 has its own slow monitoring system, consisting of a beam sampler, a slow monitoring fiber, a photo-diode, a spectrometer and a digital scope. Its pulse is delivered to the ECAL detector through one of the channels in the 5 × 1 optical switch. The laser and its ancillary optics are controlled by a stand-alone PC which communicates with the PC controlling the Quantronix lasers via Ethernet.

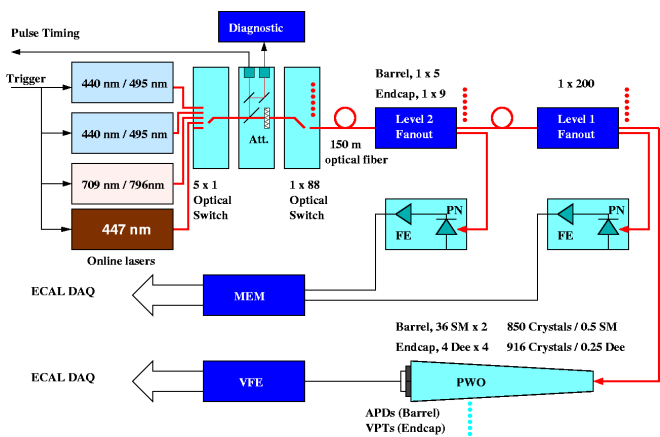

Fig. 12. DP2-447 integrated into the CMS monitoring laser system.

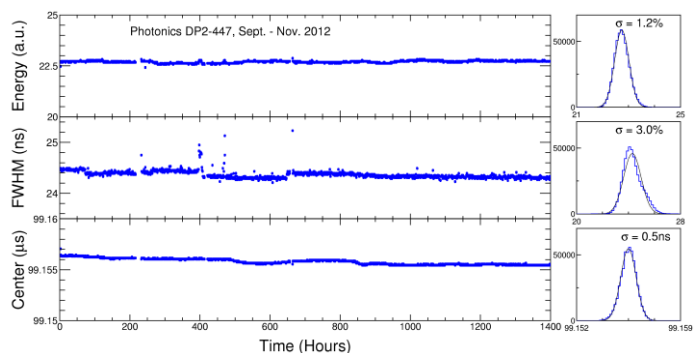

Fig. 13. History of the DP2 laser pulse energy, width and timing measured in situ at LHC.

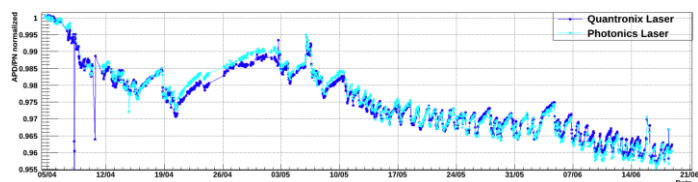

Fig. 14. Comparison of the laser monitoring responses obtained with Quantronix and Photonics lasers *in situ* at LHC.

Fig.13 shows a typical history plot for the DP2-447 pulse energy, width and center timing *in situ* at LHC and their stabilities over 1,400 hours. The results show that the stability of the laser pulse energy, width and jitter are at 1.2%, 3% and 0.5 ns respectively, exceeding the 3%, 5% and 3 ns specifications. The comparison between responses of Quantronix and Photonics lasers is shown in Fig. 14. The overall consistency between these two lasers is excellent.

### IV. SUMMARY

A new DPSS DP2-447 blue laser was successfully commissioned at CERN for the 2012 operation. This laser uses an Nd:YVO<sub>4</sub> crystal and a proprietary intra-cavity frequency triple technology. It has a simple structure and compact design, and is more reliable than the existing lamp-pumped lasers. Measurements at Caltech and *in situ* at LHC show that this

DP2-447 laser has good stabilities of 1%, 2% and 1 ns for the laser pulse energy, width and centre timing respectively. This new blue laser system provides a good foundation for precision monitoring of the 75,848 channels in the CMS ECAL *in situ* at LHC.

#### ACKNOWLEDGMENT

The authors would like to thank CMS ECAL colleagues for the collaborative effort on the work presented in this paper. This work was supported in part by the US Department of Energy Grant DE-FG03-92-ER40701.

#### REFERENCES

- [1] The CMS Collaboration, Phys. Lett. B716 (2012) 30-61.
- [2] 2008 JINST 3 S08004
- [3] 2010 JINST 5 T03010
- [4] See, for example, N-35-4 in this conference record.
- [5] X. Qu, L. Zhang and R.-Y. Zhu, 2000 *IEEE Trans. Nucl Sci* 47, 1741.
- [6] M. Anfreville *et al.*, 2008 *Nucl Inst. And Meth A*594, 292.
- [7] L. Zhang, K. Zhu, D. Bailleux, A. Bornheim and R.-Y. Zhu, 2008 *IEEE T Nucl Sci* 55, 637.